

URBAN SKETCHING 2024



Reference

- All slides at: www.peterloebel.ca

Overview

- Day 1 Materials / Perspective
- Day 2 Warm Up / Composition
- Day 3 Warm Up / Proportion and Scale
- Day 4 Warm Up / Details, Observation
- Day 5 Warm Up / Value
- Day 6 Warm Up / Practice

WHAT IS URBAN SKETCHING?

- Nonprofit Organization formed in 2007:
<http://www.urbansketchers.org/>
- A Global Community of Artists Who Practice and Share On-Location Drawing
- Victoria Local Chapter on Facebook

WHAT IS URBAN SKETCHING?



Kiah Kiean



João Paulo
Albergaria

WHAT IS URBAN SKETCHING?



Marc Taro Holmes



Simone Ridyard

WHAT IS URBAN SKETCHING?

Victoria Urban Sketchers
Works by: Cheryl, Inge,
Lindsay

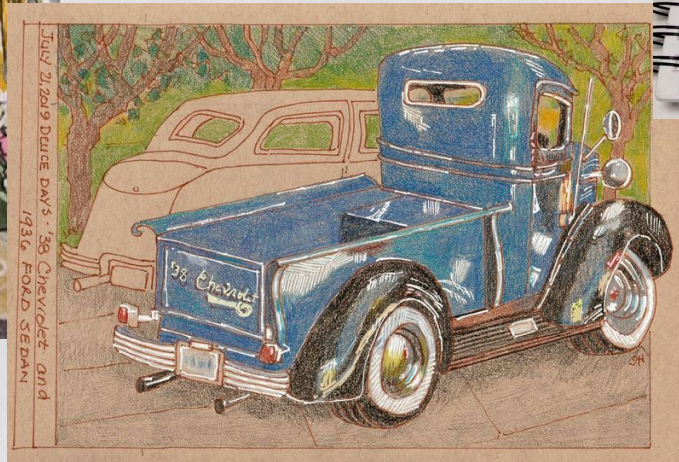
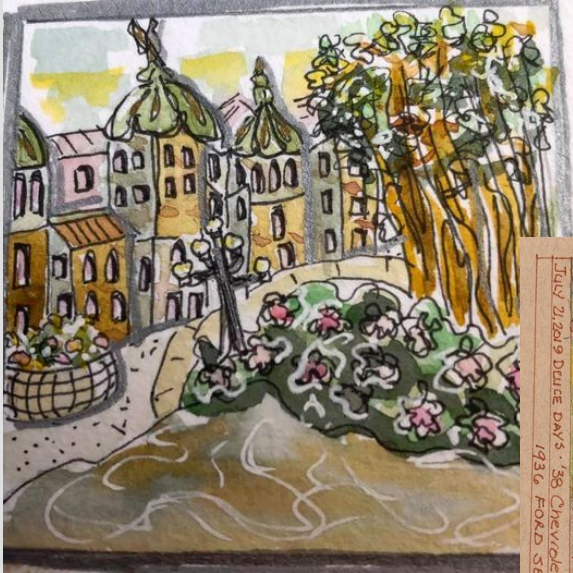

REFERENCES

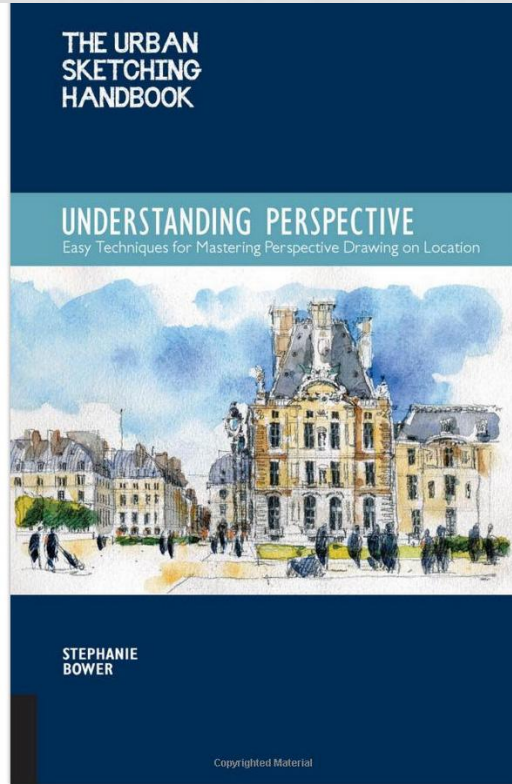

Books by:
Marc Taro Holmes (right)
Stephanie Bower (left)

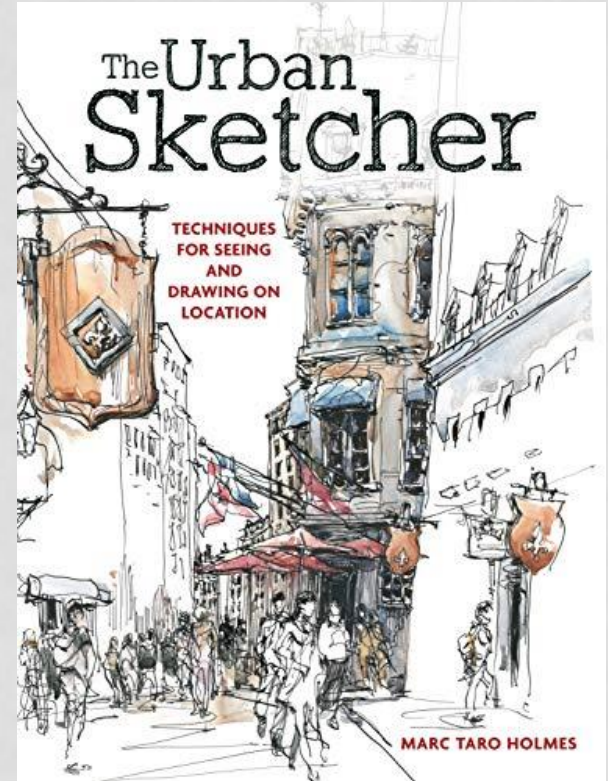

MY URBAN SKETCHING

Pencil:

As little as possible

Ink:

As much as needed

Watercolour:

As much as necessary

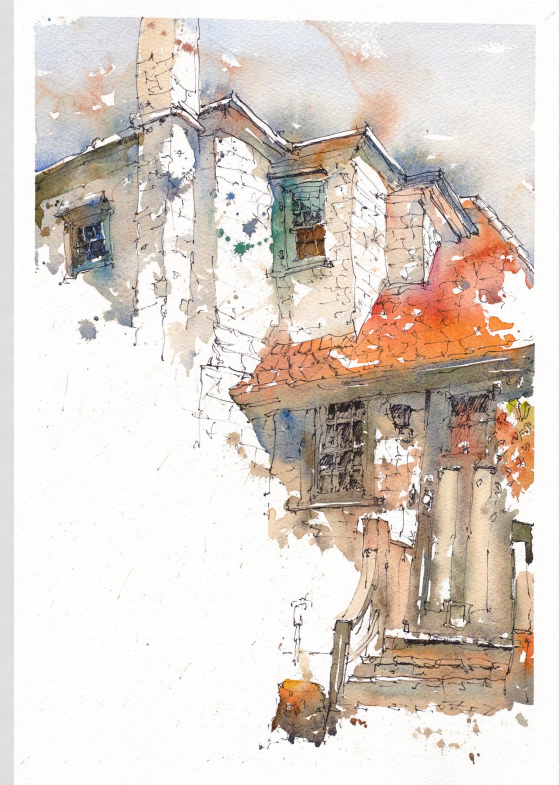

WHY INK ?

- Permanence
- Easy to transport
- Value range

Kiah Kiean

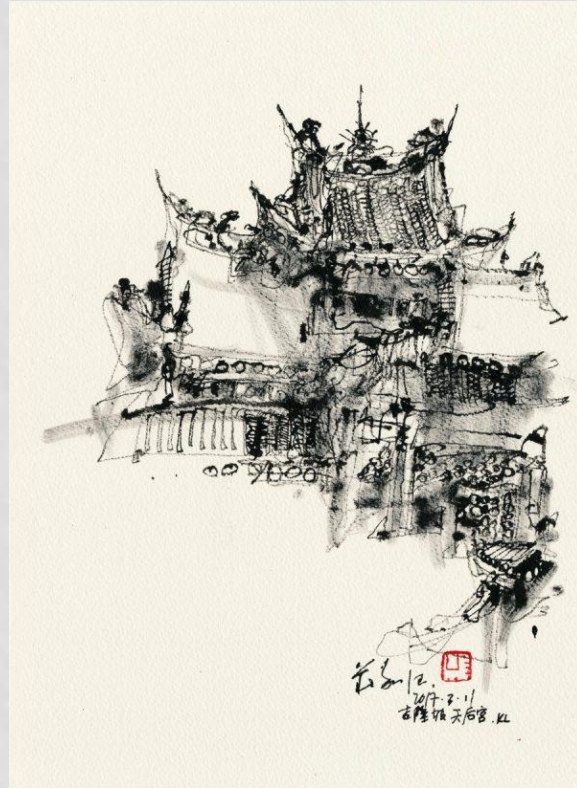

MATERIALS

- Go light, less is more
 - All equipment can fit in a mid-sized backpack
- Be comfortable, be flexible
 - Chair, small umbrella (silver!), sun hat
- Plan ahead
 - Local art supply (paper)
 - Water supply etc.



MATERIALS

- Comfort



MATERIALS

- Sketching Tools 1

- HB Pencil
- Uni-Ball Fine
 - Waterproof (pigment)
- (Brush Pen)
 - Kuretake
 - Pentel Art Brush
 - Molotow Blackliner S
- Eraser



MATERIALS

- Sketching Tools 2
 - Pen and nib
 - Use waterproof ink!



MATERIALS

- Sketching Tools 3
 - Fountain pen
 - Problem: Most waterproof inks will clog your fountain pen, so use:
 - Noodler's Bulletproof
 - Platinum Carbon Ink
 - De Atramentis Ink



PAPER

- Cheap sketchbook for layout and doodles:
 - Opus
 - Strathmore etc.



PAPER 1

- Sheets 100% Cotton
- Hot Pressed, Cold Pressed (NOT),
Rough
 - Arches, Waterford Sanders,
Fabriano Artístico, Opus Finest
- Full sheet (30 x 22 in)
- Half sheet (22 x 15 in) or (30 x 11)
- Quarter sheet (11 x 15 in)
- Exotic formats

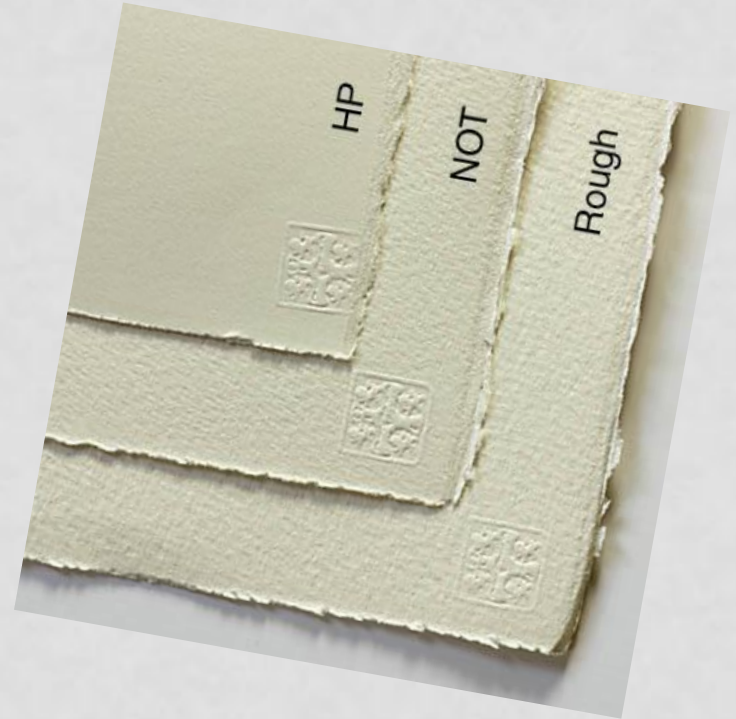

PAPER 1

- Weight
 - 90 lb (200g)
 - 140 lb (300g)
 - 300 lb (600g)

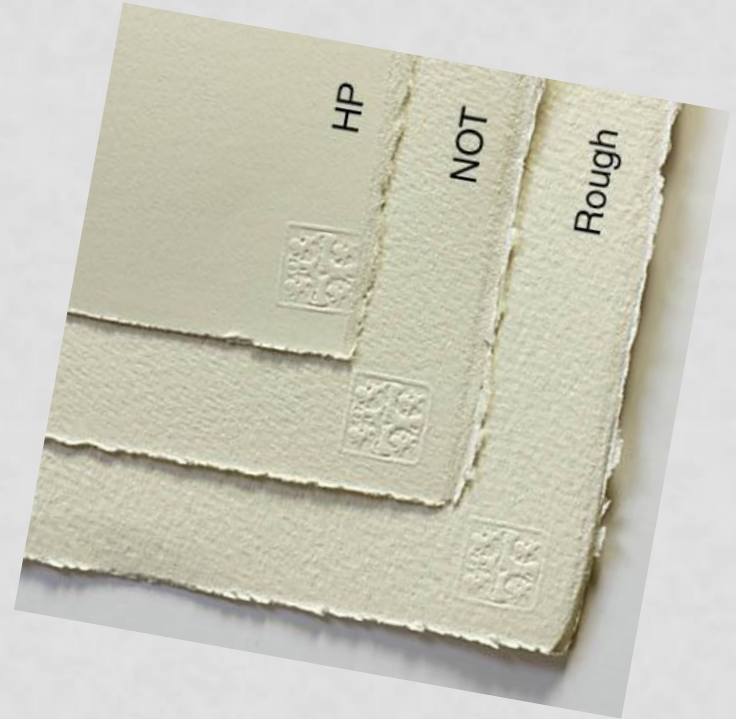

PAPER 2

- Blocks
 - Glued on outside
 - Buy 100% Cotton!



PAPER 3

- Watercolour Books and Pads
 - Moleskine
 - Hahnemuehle
 - Make your own book

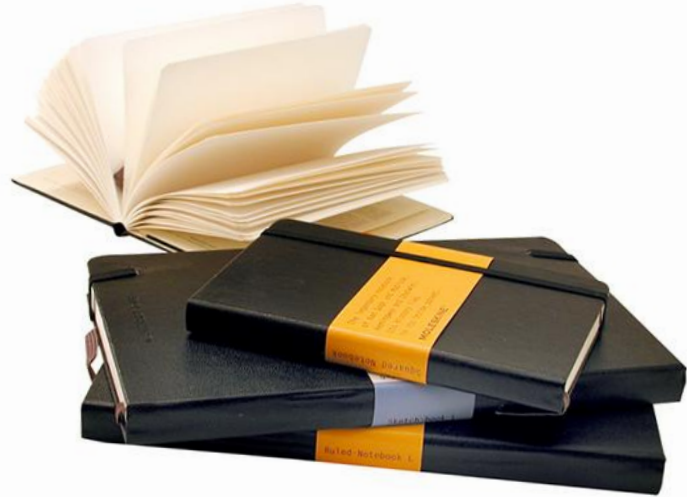

PAPER 4

- Travelogue
 - Collage with text, tickets, postcards...



Warm Up

- Warm up on cheap paper 2 x 5 minutes

PERSPECTIVE

Representation of Depth:

- Contrast (Less contrast in the background)
- Color (cooler in the background at daytime)
- Linear Perspective



LINEAR PERSPECTIVE

Only use lines
that are parallel
to the ground!!!
“True horizontal”

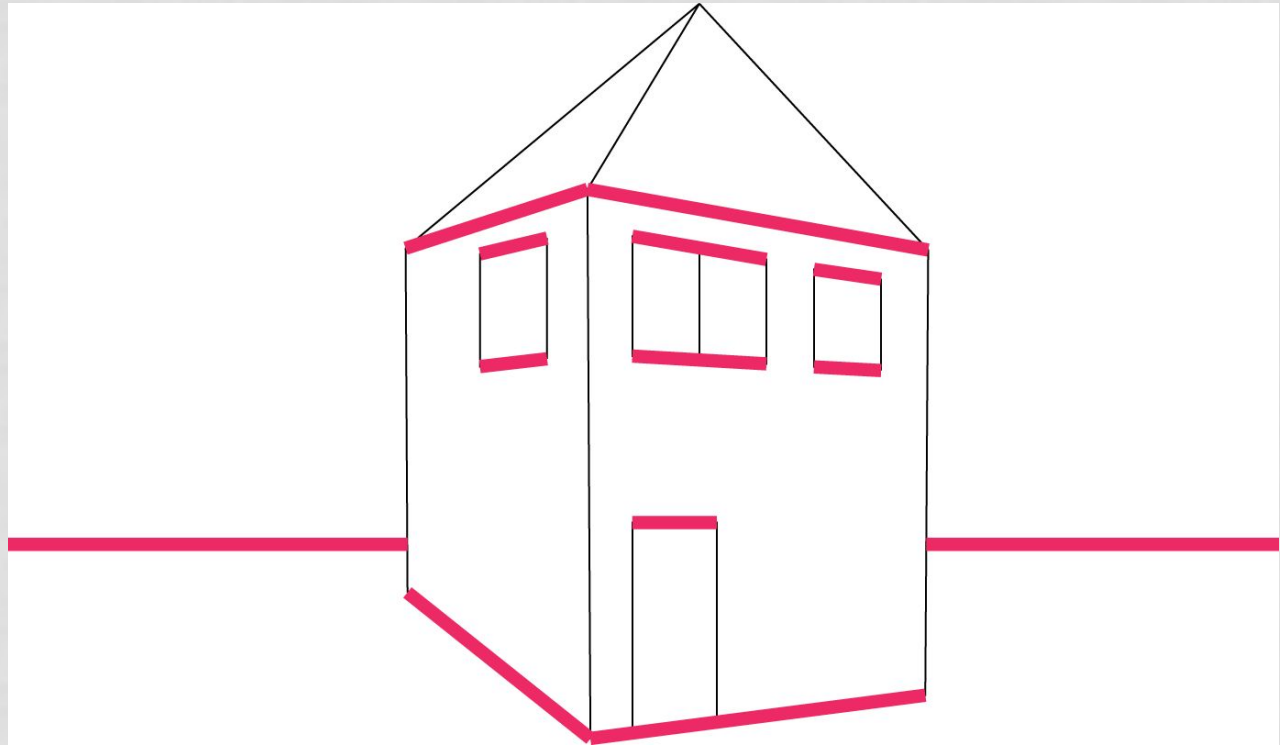

LINEAR PERSPECTIVE

Straight on view
“Elevation”

Horizontal lines
remain horizontal
in drawing

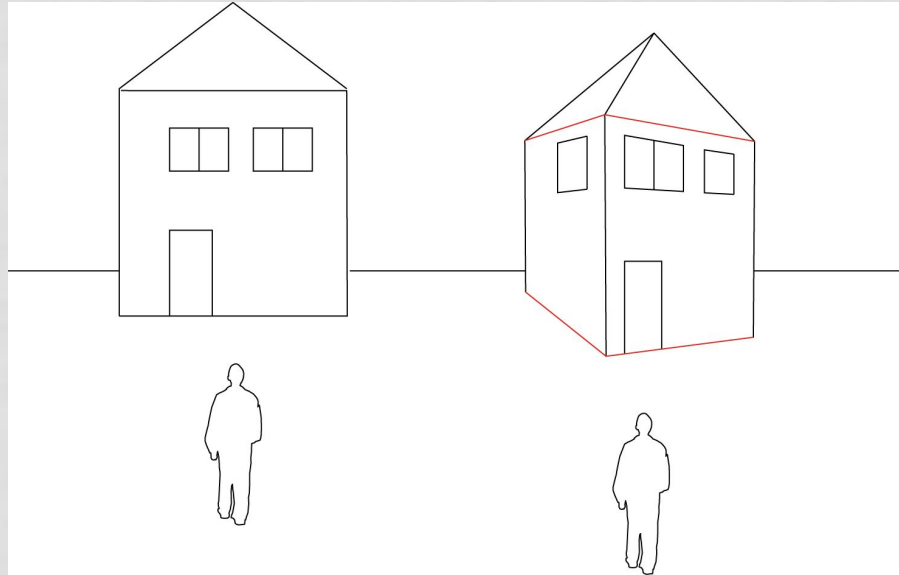

Angled View
“Perspective”

Horizontal lines
appear tilted

LINEAR PERSPECTIVE

Straight on View
“Elevation”

Lines parallel to the ground
remain horizontal on paper



LINEAR PERSPECTIVE



Angled View
“Perspective”

Lines parallel to the
ground (true
horizontal) appear
tilted on photo and
paper

PERSPECTIVE

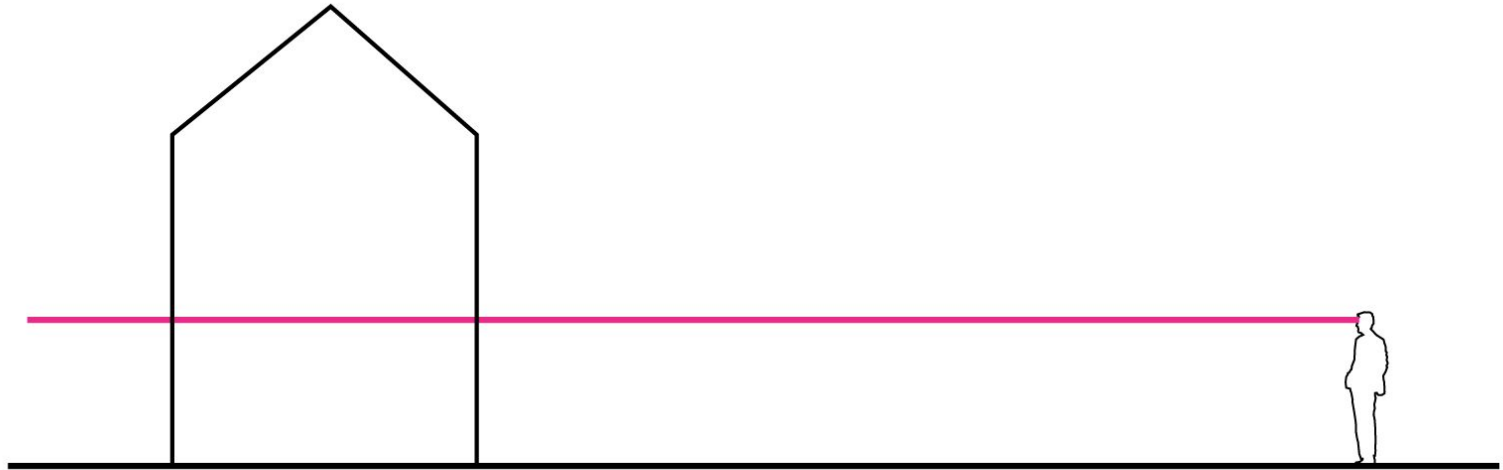

Eye Level=Horizon Line

PERSPECTIVE

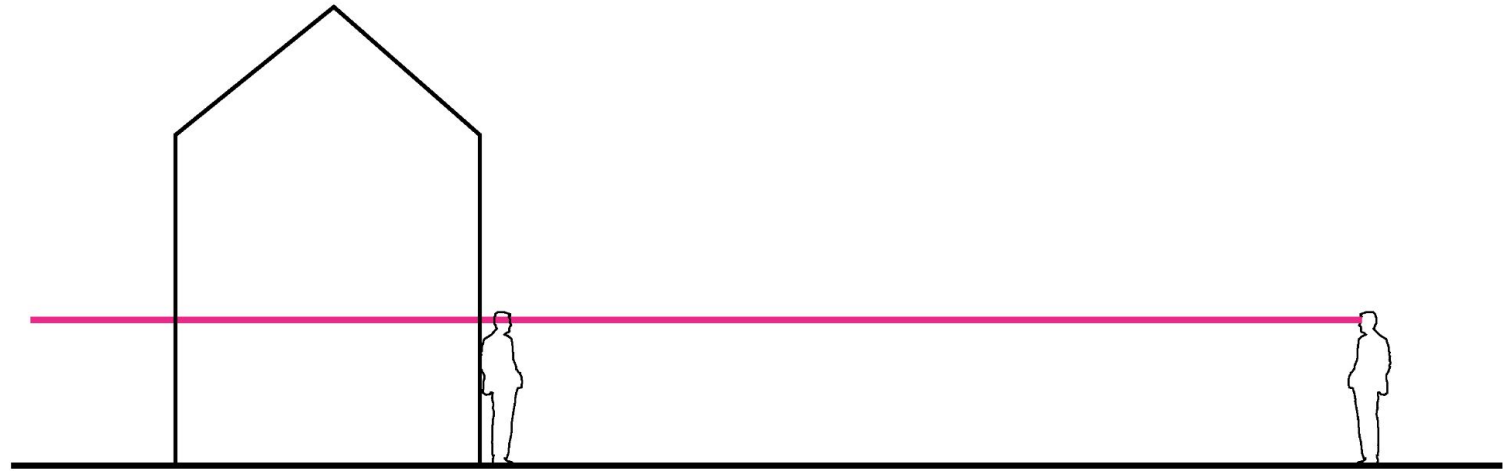

Eye Level=Horizon Line

PERSPECTIVE

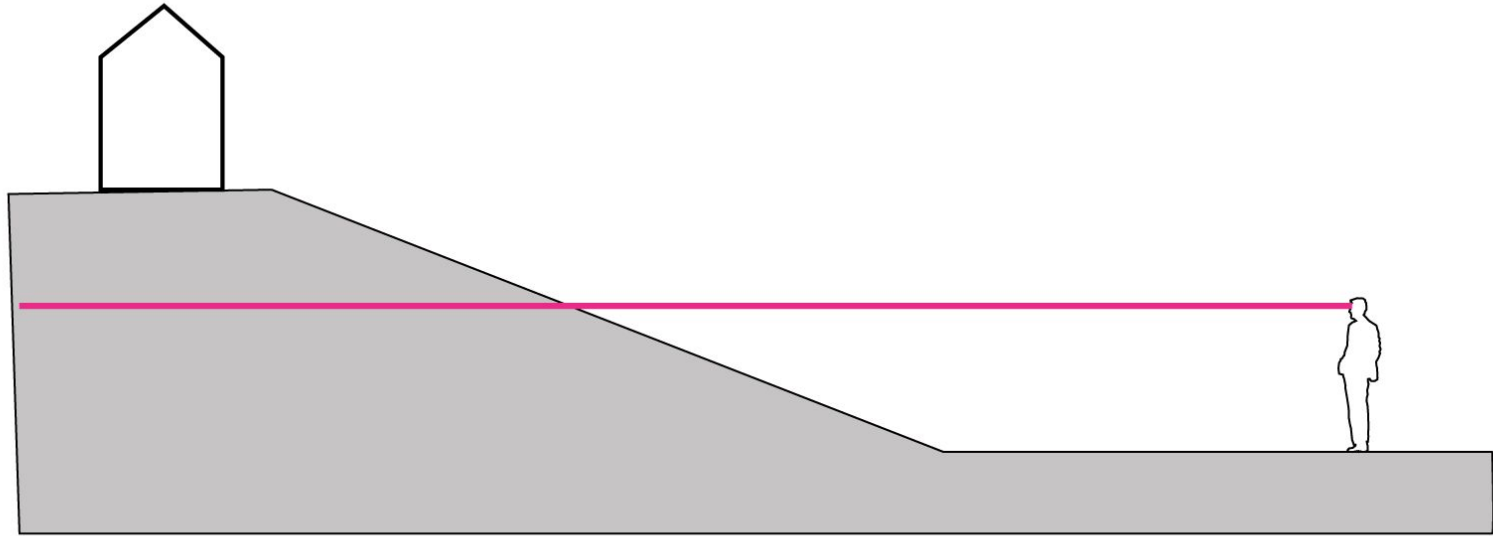

Eye Level=Horizon Line

PERSPECTIVE

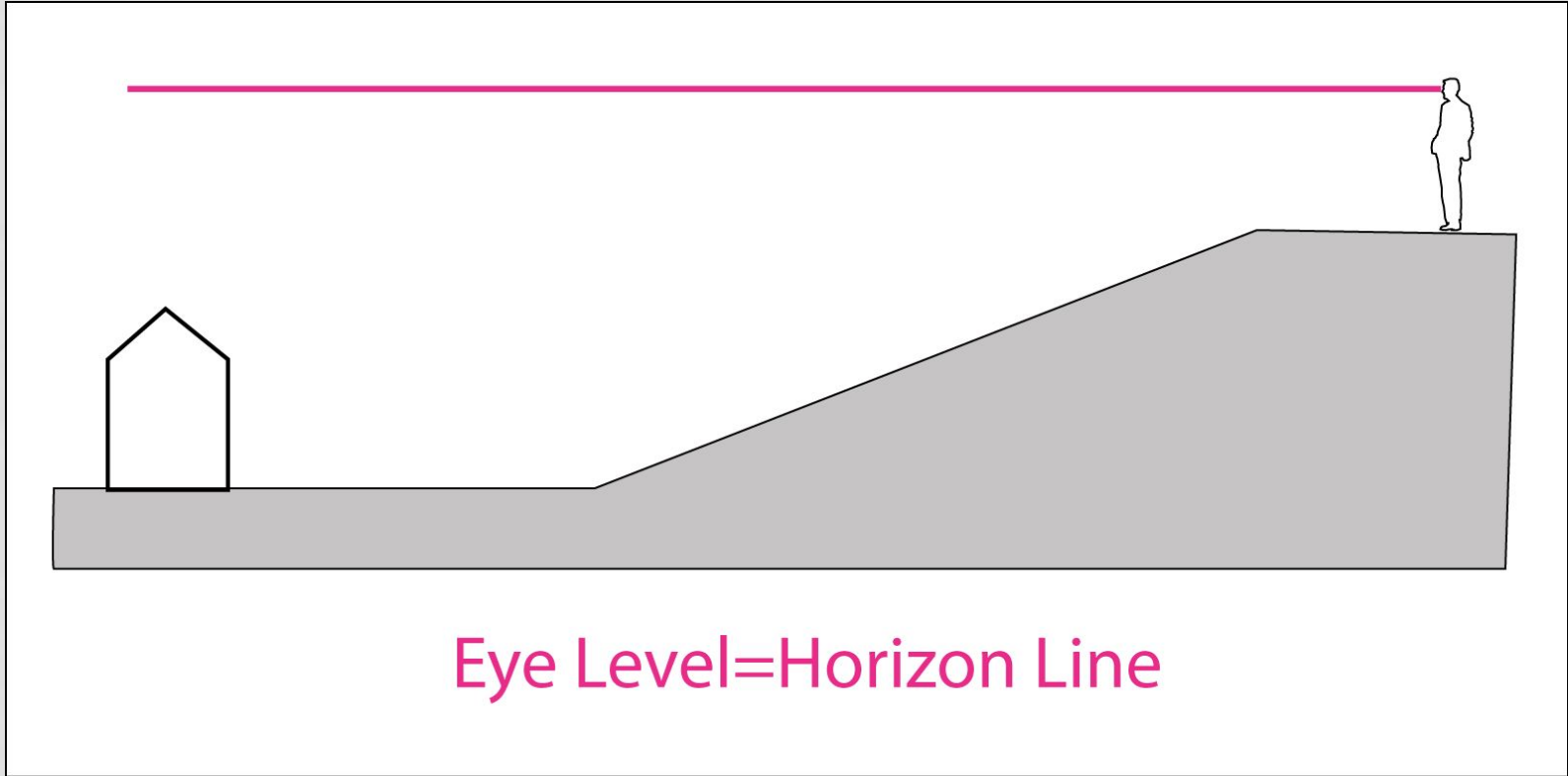

PERSPECTIVE



PERSPECTIVE



PERSPECTIVE



PERSPECTIVE

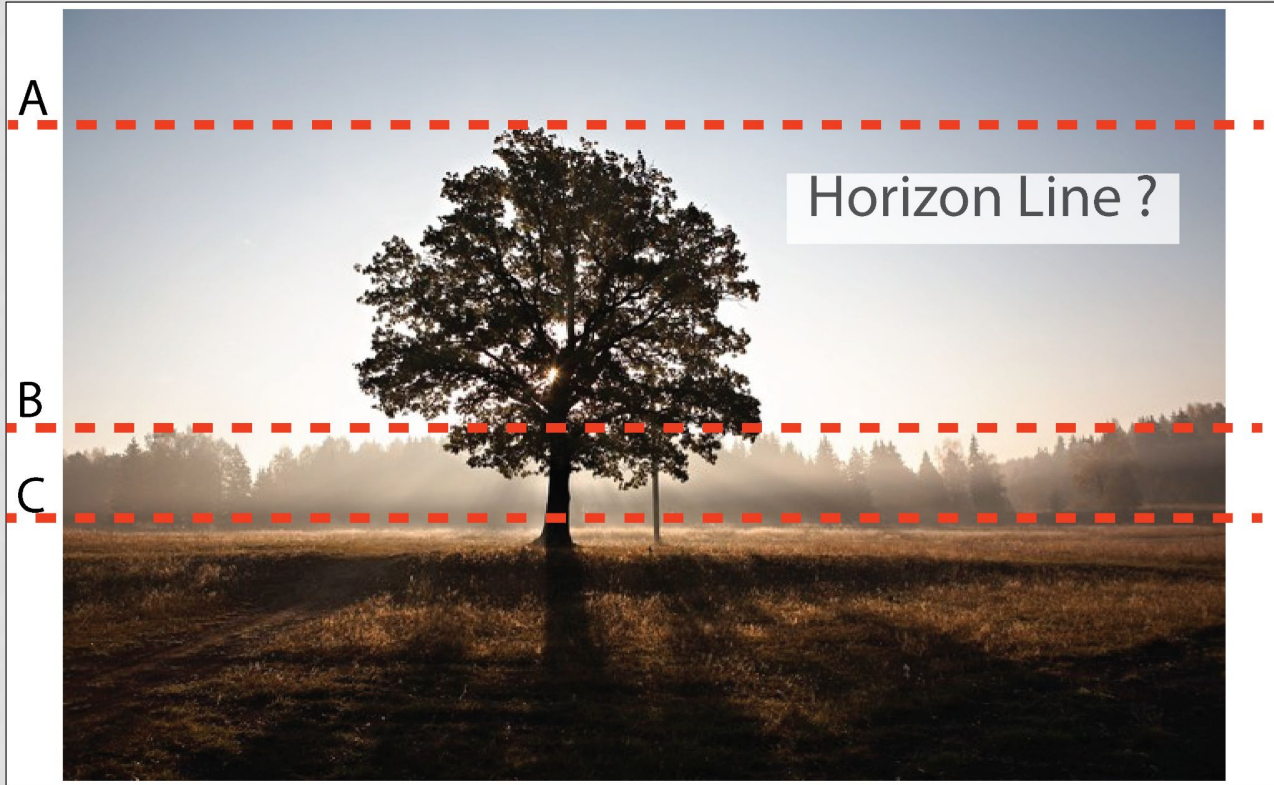

PERSPECTIVE



PERSPECTIVE

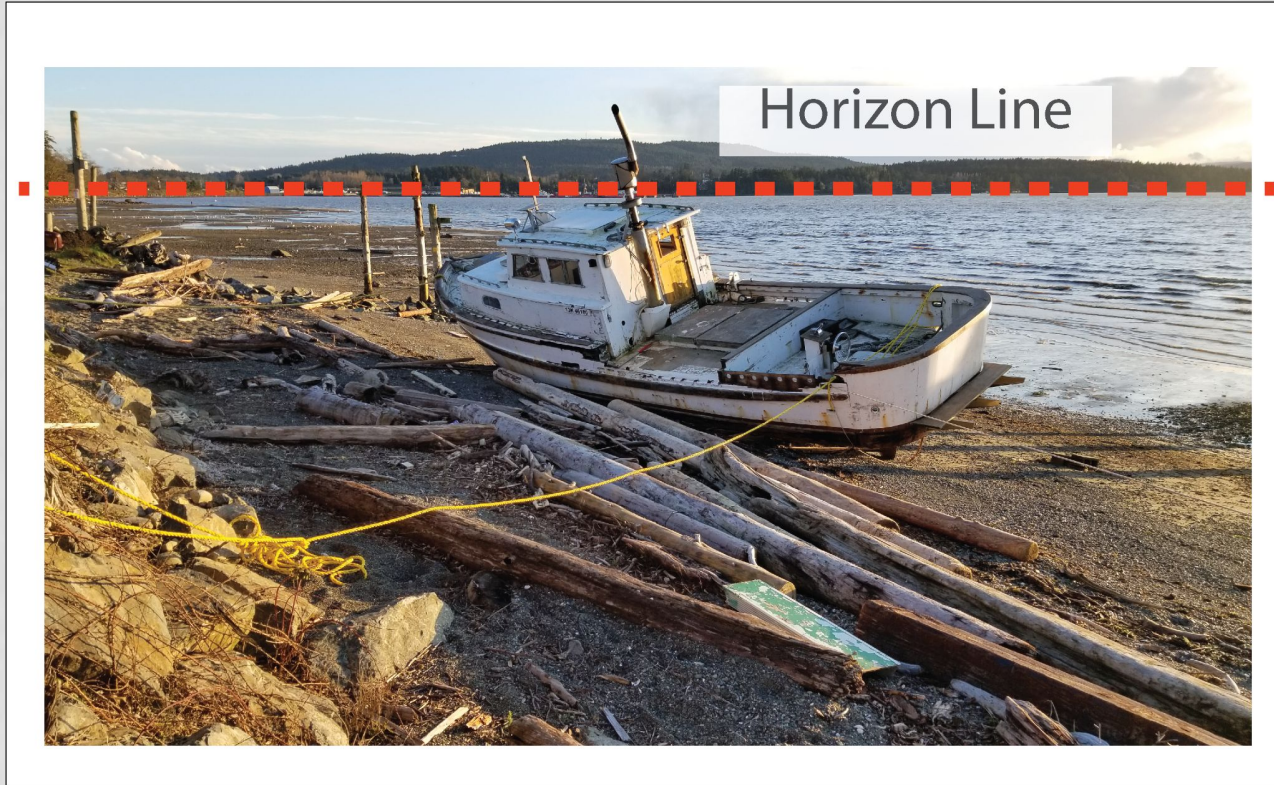

PERSPECTIVE

Horizon Line ?



PERSPECTIVE

“Tracing”

- Real World
- Photo



PERSPECTIVE

Practice



PERSPECTIVE



What is the process? (1) Find Eye Level

PERSPECTIVE



Eye Level = Horizon Line

PERSPECTIVE

2 - Point perspective



Simplification: Vertical Lines parallel

PERSPECTIVE



PERSPECTIVE



PERSPECTIVE

Vanishing Points



PERSPECTIVE

Vanishing Points



Second vanishing point

PERSPECTIVE



Parallel faces have the same Vanishing Point!

PERSPECTIVE EXERCISE 1

- Which lines are parallel to the ground?
- Find Vanishing Points
- Construct doors and windows for each side

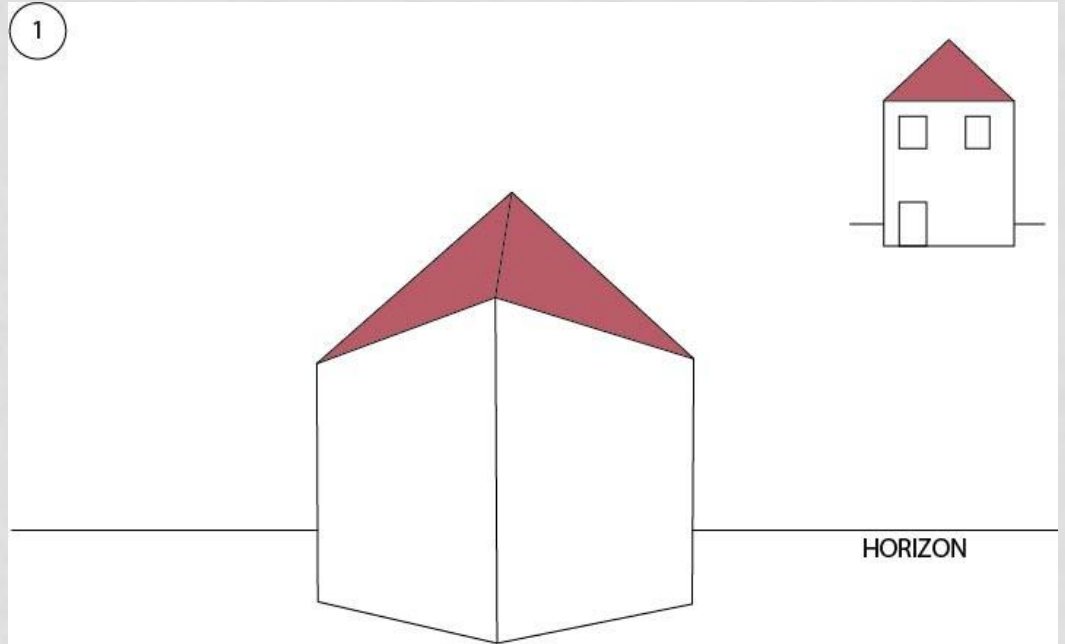

PERSPECTIVE EXERCISE 2

- What if the Vanishing Point is off the page?

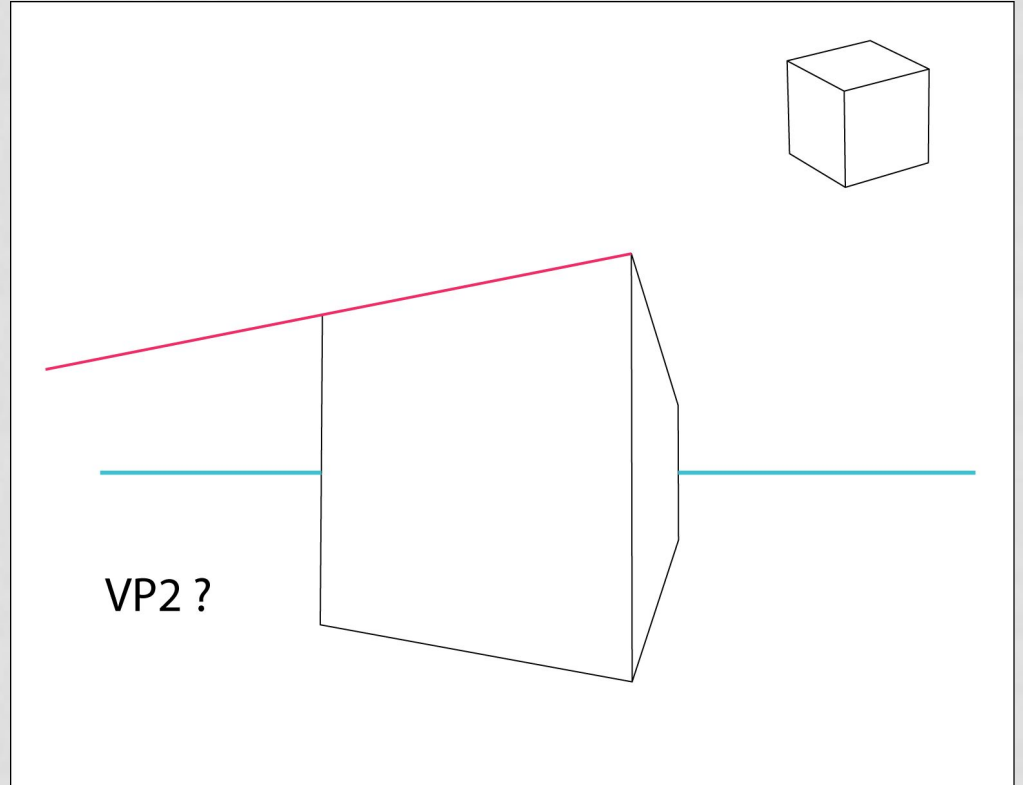

PERSPECTIVE EXERCISE 2

- What if the Vanishing Point is off the page?

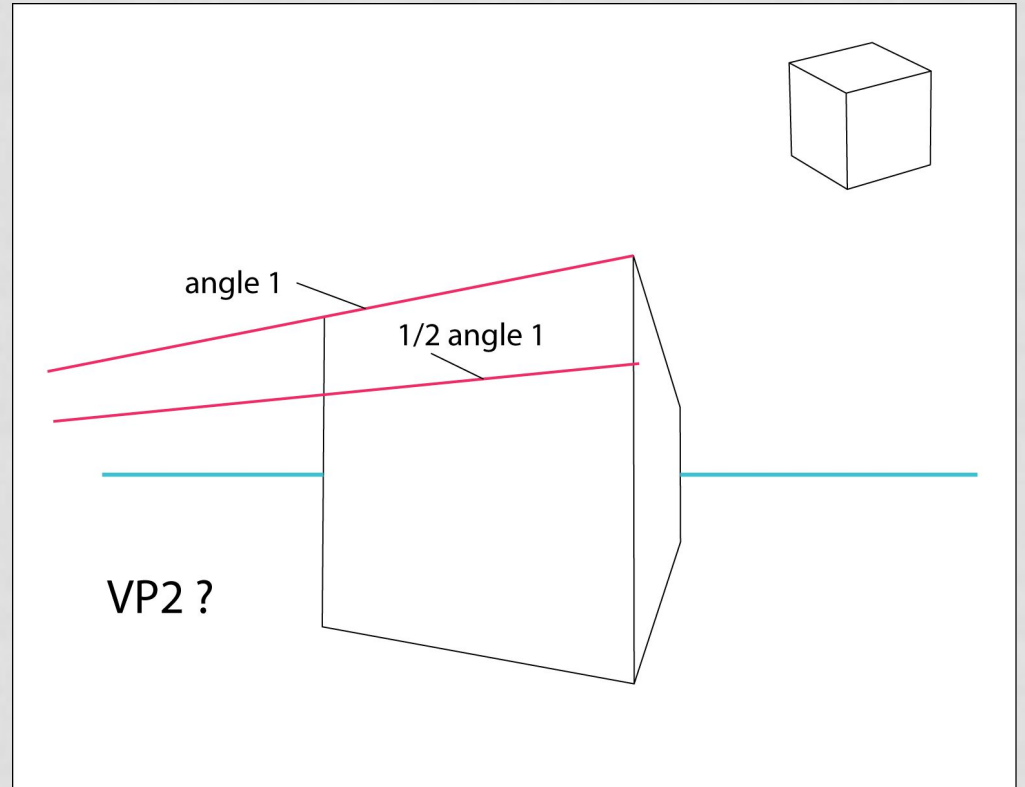

PERSPECTIVE

Where is the
Horizon Line
/ Eye Level?



PERSPECTIVE

HL



PERSPECTIVE



PERSPECTIVE

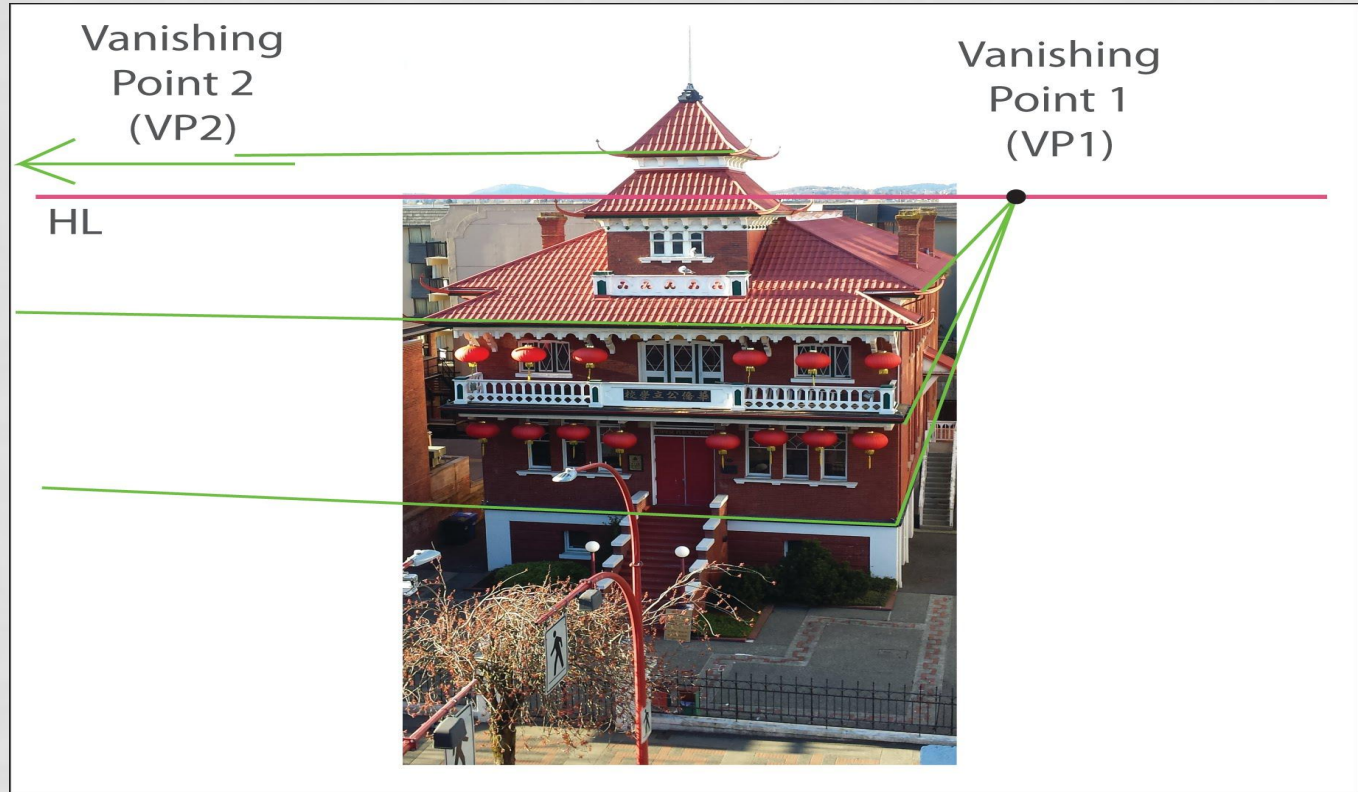

PERSPECTIVE EXERCISE

- From one selected photo (Perspective):
 - Draw perspective view on your sketch paper (omit details!)
 - Find Horizon Line = Eye Level
 - Start with first side (e.g. North or East elevation)
 - Find Vanishing Point 1 for this side (top line meets Eye Level)
 - Connect more construction lines to Vanishing Point

PERSPECTIVE EXERCISE

- From one selected photo (Perspective):
 - Continue from previous sketch:
 - Repeat for Vanishing Point 2 for the other side (plane)
 - Are there other (parallel) planes that share VP1 or VP2?

PERSPECTIVE



1 - POINT PERSPECTIVE

PERSPECTIVE



PARALLEL PLANES → SAME VANISHING POINT!

PERSPECTIVE

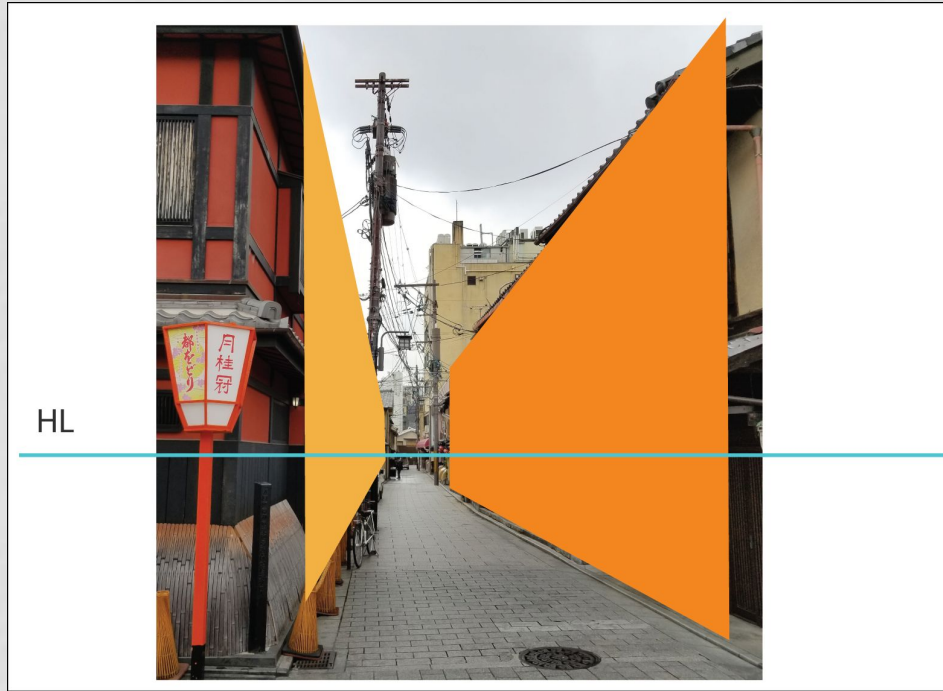

FIND HORIZON LINE (= EYE LEVEL)

PERSPECTIVE



FIND VANISHING POINT

PERSPECTIVE



VANISHING LINES MEET AT SINGLE VP

PERSPECTIVE

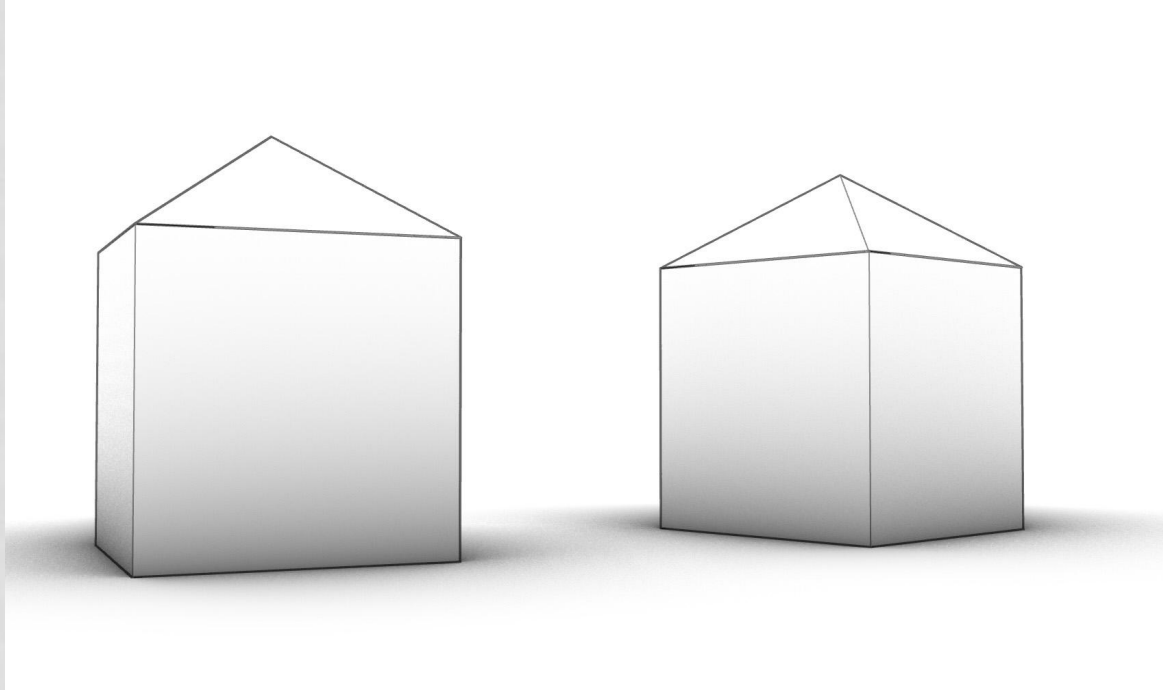

FORESHORTENING

PERSPECTIVE

- Is the observer standing or sitting?

